

- NOTE(S):
 1. PART NUMBER, "/00" DENOTES PART SHALL HAVE FINISH.
 2. APPLY NSF COMPLIANT GREASE TO ANY O-RING, SEALING JOINTS, AND/OR PIVOTAL POINTS.
 3. APPLY NSF COMPLIANT LOCTITE TO THREADED AREA.
 4. APPLY NSF COMPLIANT REMOVABLE (BLUE) LOCTITE TO THREADED AREA.
 5. SILVER SOLDER JOINTS SHALL BE FULLY WETTED VIA CAPILLARY ACTION AND COMPLETELY NON-POROUS.

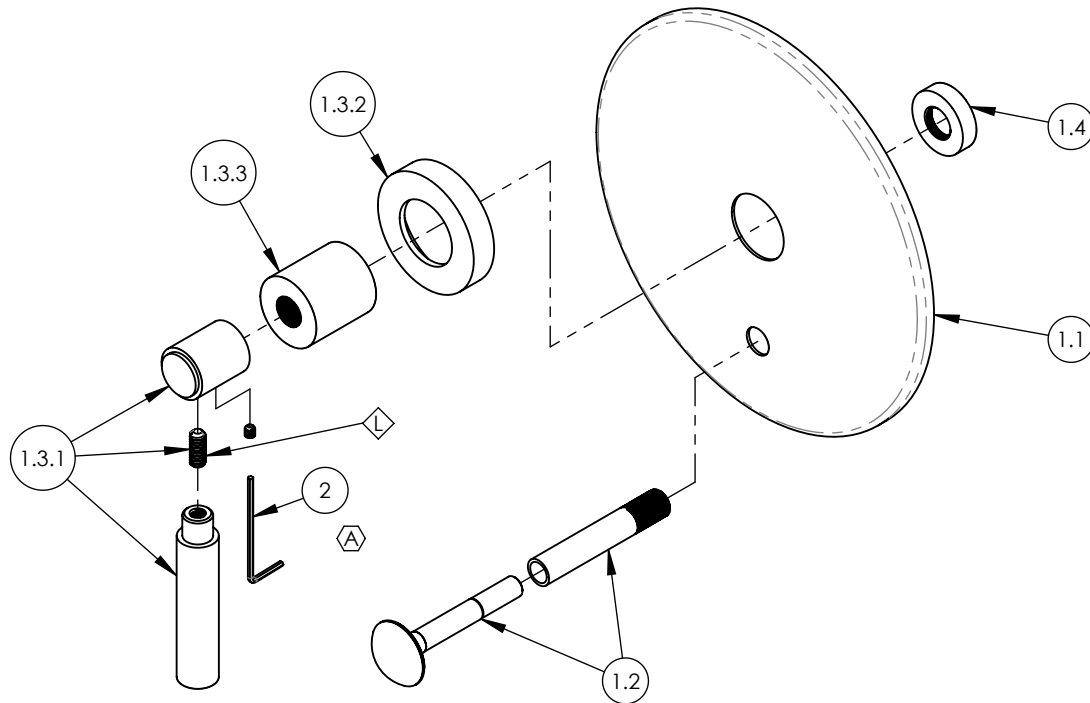

ITEM NO.	PART NUMBER	DESCRIPTION	QTY.
1	4-018/00	SHOWER TRIM PLATE W/ DIVERTER, LEVER HANDLE, BASIC	1
1.1	P20017/00	PB TRIM PLATE, BASIC	1
1.2	3-125/00	DIVERTER EXTENSION ASSY FOR PB TUB & SHOWER SET	1
1.3	3-441/00	ASSY, LEVER HANDLE, BASIC	1
1.3.1	3-408/00	ASSY, LEVER HANDLE, BASIC SERIES.	1
1.3.2	P02035_2/00	ESCUTCHEON, CONTEMPORARY	1
1.3.3	P02035_1/00	HUB ESCUTCHEON, CONTEMPORARY TOP	1
1.4	11087	SLEEVE FOR PB-THERM PLATE	1
2	92021	HEX KEY 5/64, FOR 8-32 SET SCREW	1



B4, D4	A	REMOVE SPOUT & SHOWER ASSYS, ADD TRIM PLATE ASSY, UPDATE HEX KEY	11/4/2021	AMM
ZONE	REV.	DESCRIPTION	DATE	APPROVED

REVISIONS

1261 LOGAN AVENUE
 COSTA MESA, CALIFORNIA 92626
 PHONE: 714.361.4800
 FAX: 714.617.3120

PHYLIRICH[®]
 Defining Luxury Since 1959

PROPRIETARY AND CONFIDENTIAL
 THE INFORMATION CONTAINED IN THIS DRAWING IS THE SOLE PROPERTY OF PHYLIRICH. ANY REPRODUCTION IN PART OR AS A WHOLE WITHOUT THE WRITTEN PERMISSION OF PHYLIRICH IS PROHIBITED.
DO NOT SCALE DRAWING

SHOWER TRIM PLATE, DIVERTED, LEVER TUBULAR, BASIC

SIZE A	ASM/PRT NO. DPB2130TO/00	REV A
SCALE: 1:3	WEIGHT: lbs.	SHEET 1 OF 2

5

4

3

2

1

E

E

D

D

C

C

B

B

A

A

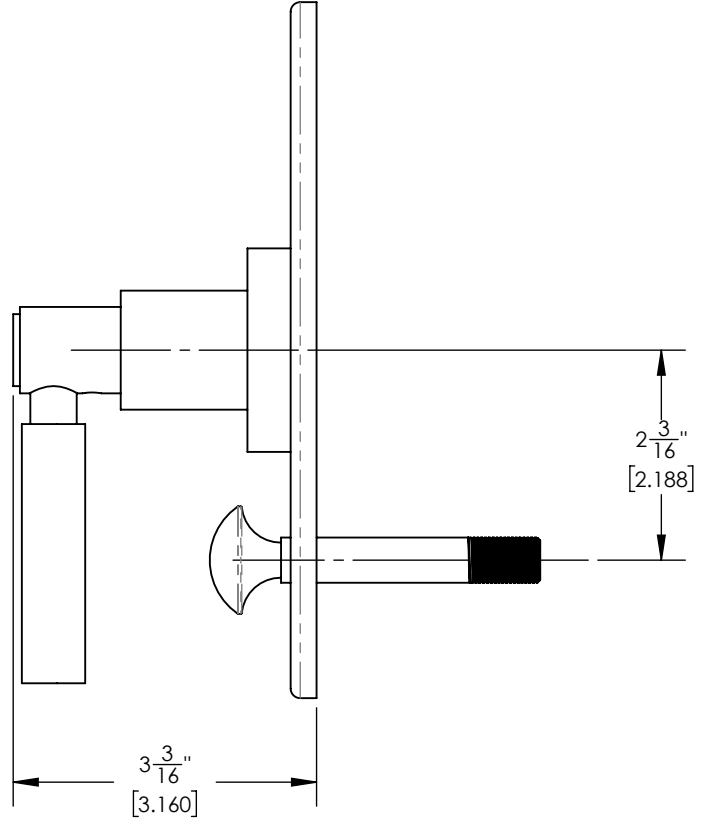
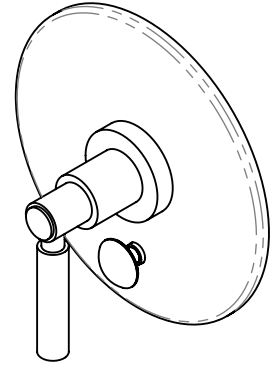
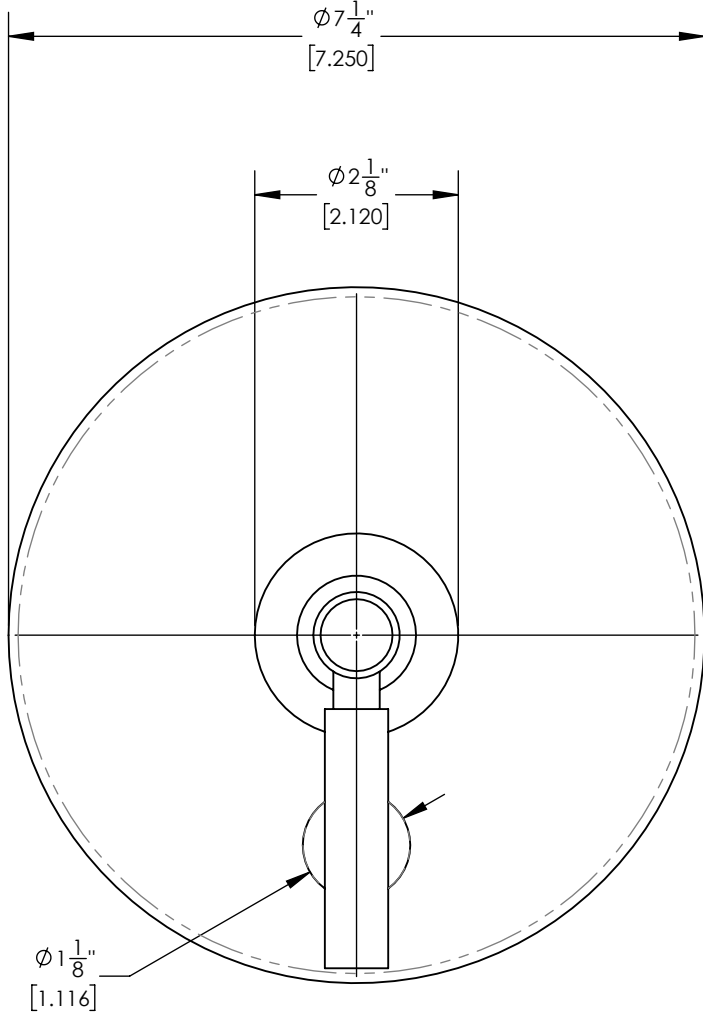

1261 LOGAN AVENUE
 COSTA MESA, CALIFORNIA 92626
 PHONE: 714.361.4800
 FAX: 714.617.3120

PHYLIRICH[®]
 Defining Luxury Since 1959

PROPRIETARY AND CONFIDENTIAL
 THE INFORMATION CONTAINED IN THIS DRAWING
 IS THE SOLE PROPERTY OF PHYLIRICH. ANY
 REPRODUCTION IN PART OR AS A WHOLE
 WITHOUT THE WRITTEN PERMISSION OF PHYLIRICH
 IS PROHIBITED.
DO NOT SCALE DRAWING

SHOWER TRIM PLATE, DIVERTED, LEVER
 TUBULAR, BASIC

SIZE A	ASM/PRT NO. DPB2130TO/00	REV A
SCALE: 1:2	WEIGHT: lbs.	SHEET 2 OF 2

5

4

3

2

1