

- NOTE(S):
 1. PART NUMBER, "/00" DENOTES PART SHALL HAVE FINISH.
2. APPLY NSF COMPLIANT GREASE TO ANY O-RING, SEALING JOINTS, AND/OR PIVOTAL POINTS. G
3. APPLY NSF COMPLIANT LOCTITE TO THREADED AREA. L
4. APPLY NSF COMPLIANT REMOVABLE (BLUE) LOCTITE TO THREADED AREA. B
5. SILVER SOLDER JOINTS SHALL BE FULLY WETTED VIA CAPILLARY ACTION AND COMPLETELY NON-POROUS. S
6. FOR DEEPEER ESCUTCHEON:
 • 3-587/00 C
 • 92401 C

ITEM NO.	PART NUMBER	DESCRIPTION	QTY.
1	3-125/00	DIVERTER EXTENSION ASSY FOR PB TUB & SHOWER SET	1
2	3-584/00	ASSY, BLADE HANDLE, ROND	1
2.1	11749/00	ESCUTCHEON, HANDLE, ROND	1
2.2	11748/00	HANDLE, BLADE, ROND	1
2.3	92005	SET SCREW, CUP PT 6-32 UNC THREAD 3/16"L	1
2.4	92176	WEAR WASHER	2
2.5	92177	RETAINING RING, 7/16" SHAFT	1
3	10445/00	TRIM PLATE 6" ROUND W/ DIVERTER HOLE, BASIC II	1
4	11003	SLEEVE MOUNT, WALL MT WIDESPREAD	1
5	90029	O-RING, 1-5/8"ID X 1-3/4"OD X 1/16"THK, AS-568-029	1

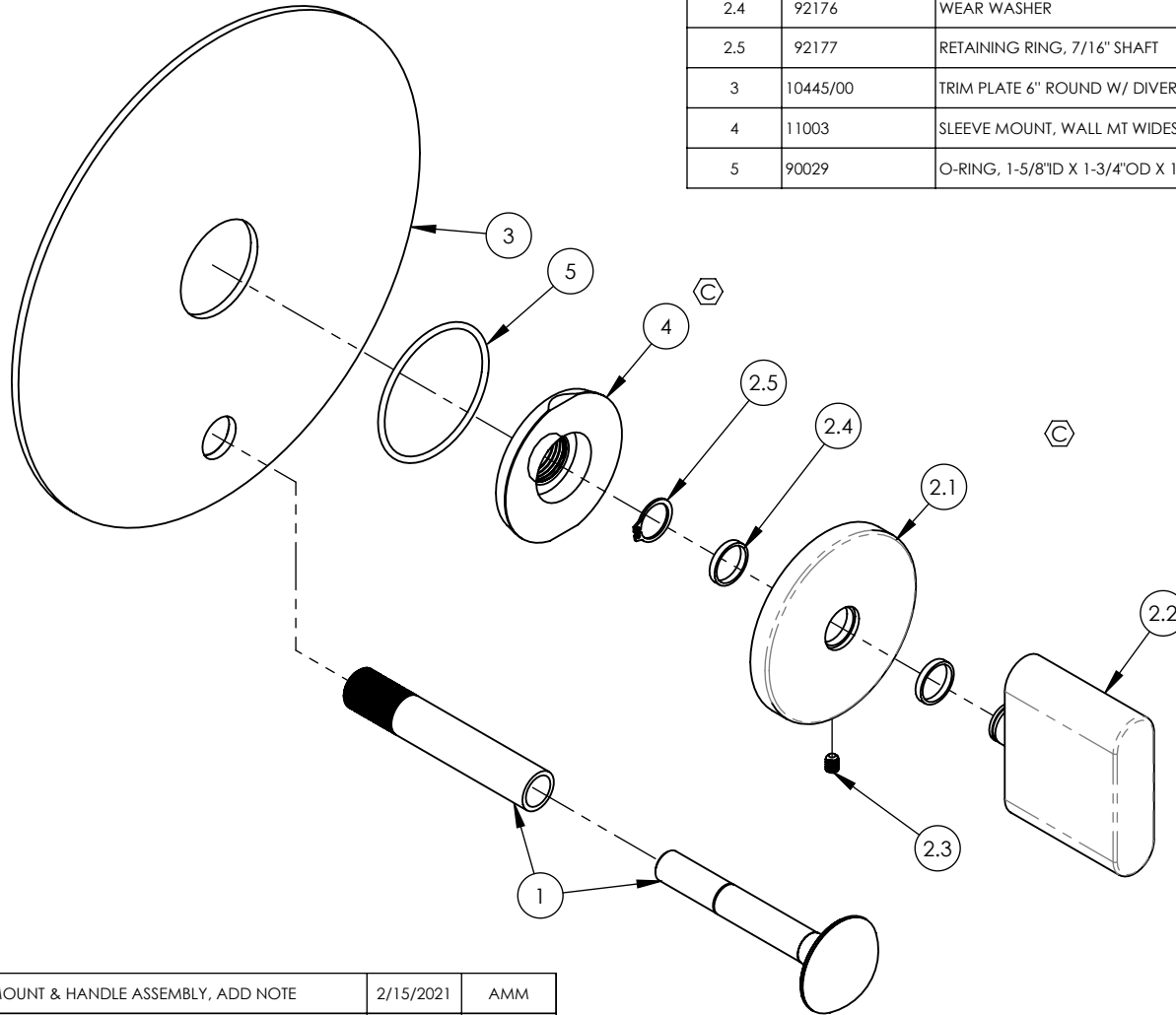

C3, C2	C	UPDATE SLEEVE MOUNT & HANDLE ASSEMBLY, ADD NOTE	2/15/2021	AMM
ZONE	REV.	DESCRIPTION	DATE	APPROVED
REVISIONS				

1261 LOGAN AVENUE
 COSTA MESA, CALIFORNIA 92626
 PHONE: 714.361.4800
 FAX: 714.617.3120

PHYLIRICH[®]
 Defining Luxury Since 1959

PROPRIETARY AND CONFIDENTIAL
 THE INFORMATION CONTAINED IN THIS DRAWING IS THE SOLE PROPERTY OF PHYLIRICH. ANY REPRODUCTION IN PART OR AS A WHOLE WITHOUT THE WRITTEN PERMISSION OF PHYLIRICH IS PROHIBITED.
DO NOT SCALE DRAWING

ASSY, BLADE HANDLE W/ DIVERTER, TRIM, ROND

SIZE A	ASM/PRT NO. 4-553/00	REV C
SCALE: 1:2	WEIGHT: lbs.	SHEET 1 OF 2

5

4

3

2

1

E

E

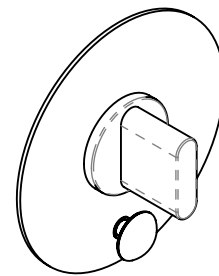

D

D

C

C

B

B

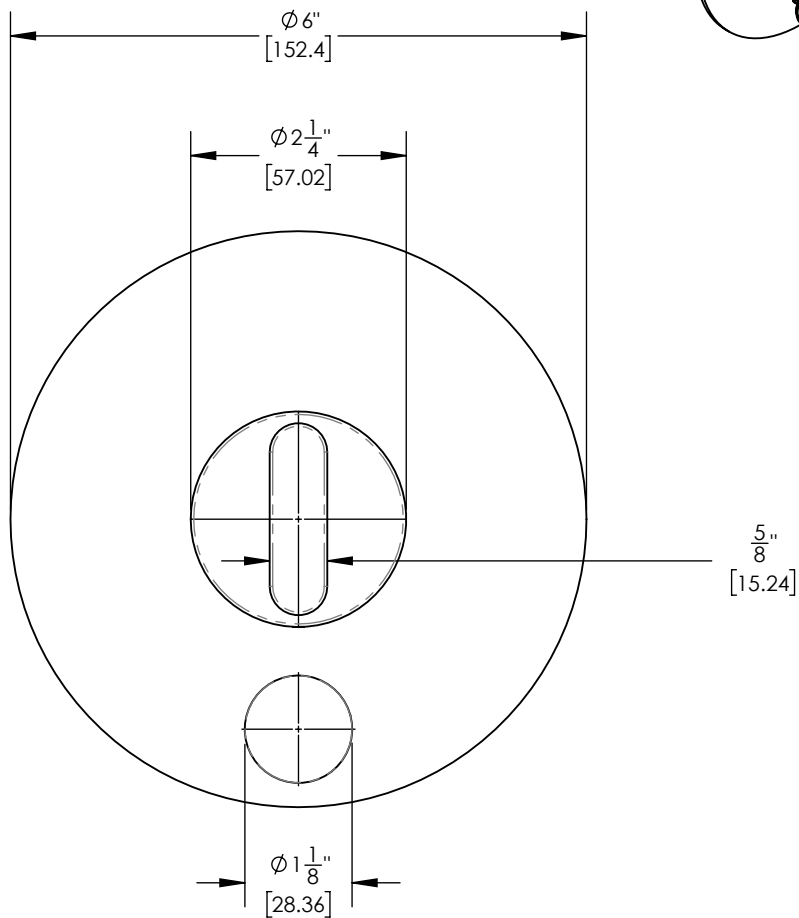
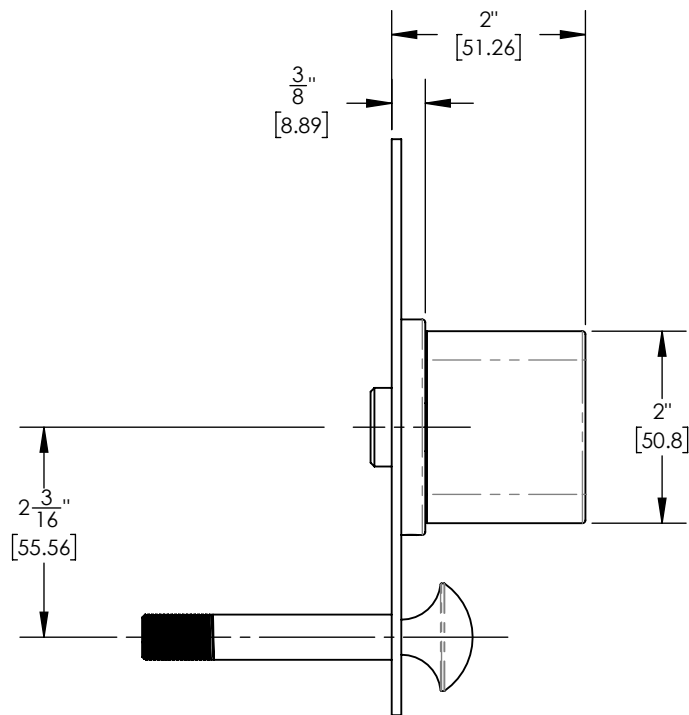

1261 LOGAN AVENUE
COSTA MESA, CALIFORNIA 92626
PHONE: 714.361.4800
FAX: 714.617.3120

PHYLIRICH[®]
Defining Luxury Since 1959

PROPRIETARY AND CONFIDENTIAL
THE INFORMATION CONTAINED IN THIS DRAWING IS THE SOLE PROPERTY OF PHYLIRICH. ANY REPRODUCTION IN PART OR AS A WHOLE WITHOUT THE WRITTEN PERMISSION OF PHYLIRICH IS PROHIBITED.
DO NOT SCALE DRAWING

ASSY, BLADE HANDLE W/ DIVERTER, TRIM, ROND

SIZE	ASM/PRT NO.	REV
A	4-553/00	C

SCALE: 1:2	WEIGHT: lbs.	SHEET 2 OF 2
------------	--------------	--------------

5

4

3

2

1

A

A