

- NOTE(S):
 1. PART NUMBER, "/00" DENOTES PART SHALL HAVE FINISH.
 2. APPLY NSF COMPLIANT GREASE TO ANY O-RING, SEALING JOINTS, AND/OR PIVOTAL POINTS.
 3. APPLY NSF COMPLIANT LOCTITE TO THREADED AREA.
 4. APPLY NSF COMPLIANT REMOVABLE (BLUE) LOCTITE TO THREADED AREA.
 5. SILVER SOLDER JOINTS SHALL BE FULLY WETTED VIA CAPILLARY ACTION AND COMPLETELY NON-POROUS.

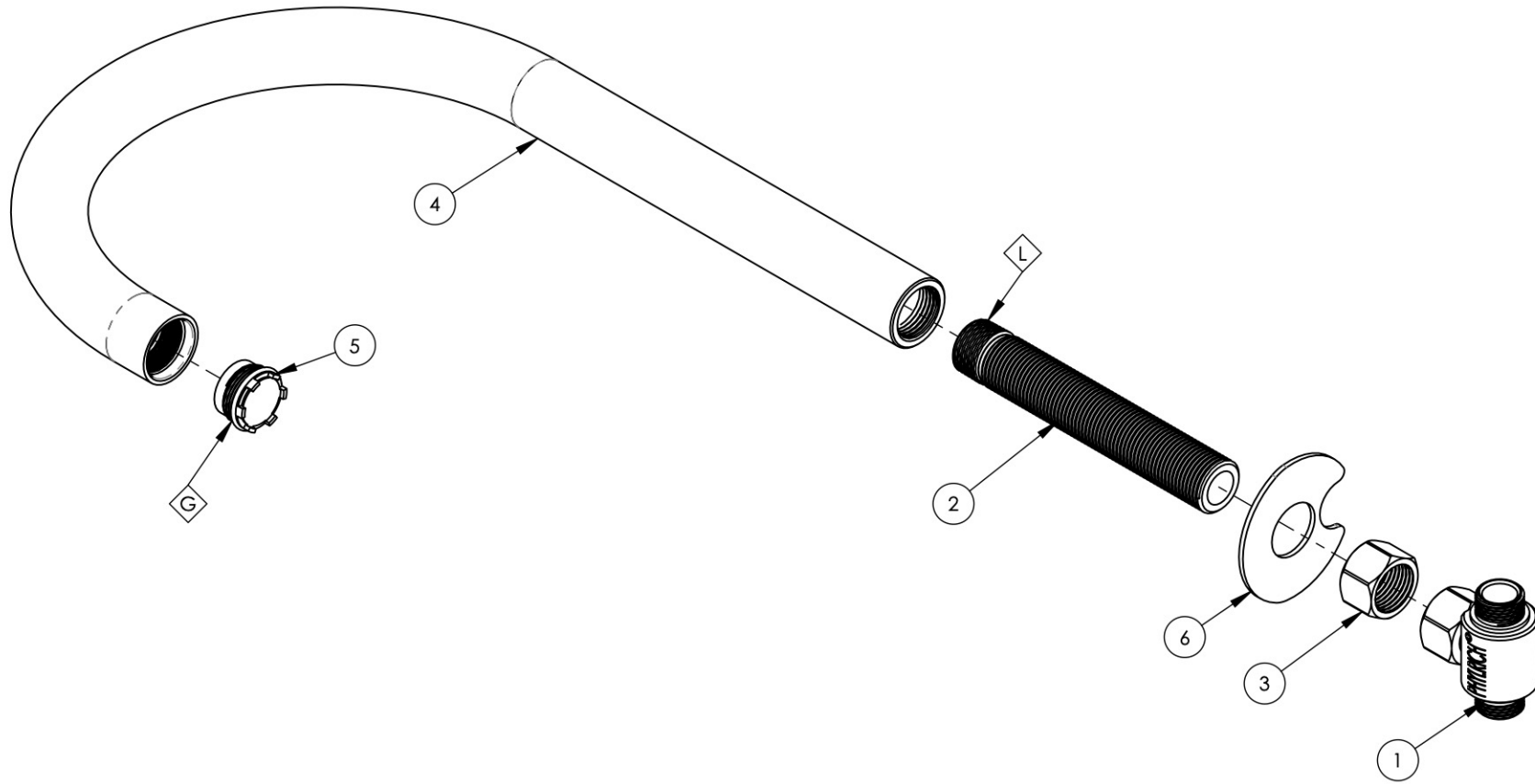

ITEM NO.	PART NUMBER	DESCRIPTION	QTY.
1	1-112	TEE VALVE, 3/8" NPSM X 3/8" COMPRESSION	1
2	10745	THREAD ALL, 3/8"-18 NPSL - 3/8"NPT	1
3	10746	NUT, 3/8"-18 NPSL	1
4	11163/00	SPOUT TUBE 3/4", LAV	1
5	11428	AERATOR, CACHE TJ, 1.2GPM PCA PINK, 43.2260.450	1
6	92174	WASHER MOUNT WIDESPREAD (3/8")	1



ZONE	REV.	DESCRIPTION	DATE	APPROVED
REVISIONS				

1261 LOGAN AVENUE
 COSTA MESA, CALIFORNIA 92626
 PHONE: 714.361.4800
 FAX: 714.617.3120

PHYLIRICH[®]
 Defining Luxury Since 1959

PROPRIETARY AND CONFIDENTIAL
 THE INFORMATION CONTAINED IN THIS DRAWING IS THE SOLE PROPERTY OF PHYLIRICH. ANY REPRODUCTION IN PART OR AS A WHOLE WITHOUT THE WRITTEN PERMISSION OF PHYLIRICH IS PROHIBITED.

-	-	INTERPRET GEOMETRIC DIMENSIONING & TOLERANCING IN ACCORDANCE WITH ASME Y14.5-2009 & ASME Y14.41-2003 STANDARDS, UNLESS OTHERWISE SPECIFIED. DIMENSIONS ARE IN INCHES. TOLERANCES ARE:		
120-02/00	-			
120-01/00	-			
NEXT ASSY	USED ON	FRACTIONS ±1/16"	DECIMALS X.X: ±.1 X.XX: ±.01 X.XXX: ±.005	ANGULAR ±2°
APPLICATION		MATERIAL	NAME	DATE
		FINISH	RAH	11/29/2018
DO NOT SCALE DRAWING		CHECKED		

ASSY, ARC SPOUT, WIDESPREAD, TRANSITION

SIZE A	ASM/PRT NO. 3-634/00	REV -
------------------	--------------------------------	----------

SCALE: 1:2 WEIGHT: lbs. SHEET 1 OF 1