

| ITEM NO. | PART NUMBER | DESCRIPTION                   | QTY. |
|----------|-------------|-------------------------------|------|
| 1        | 11338/00    | MIX/STRIA SQ. PLATE FOR EXT.  | 1    |
| 2        | 2-423/00    | STRIA DEEP ESC. W/ ADAPTER    | 1    |
| 2.1      | 11337/00    | STRIA DEEP ESCUTCHEON         | 1    |
| 2.2      | 11341       | HUB ADAPTER FOR EXT. DEEP HUB | 1    |

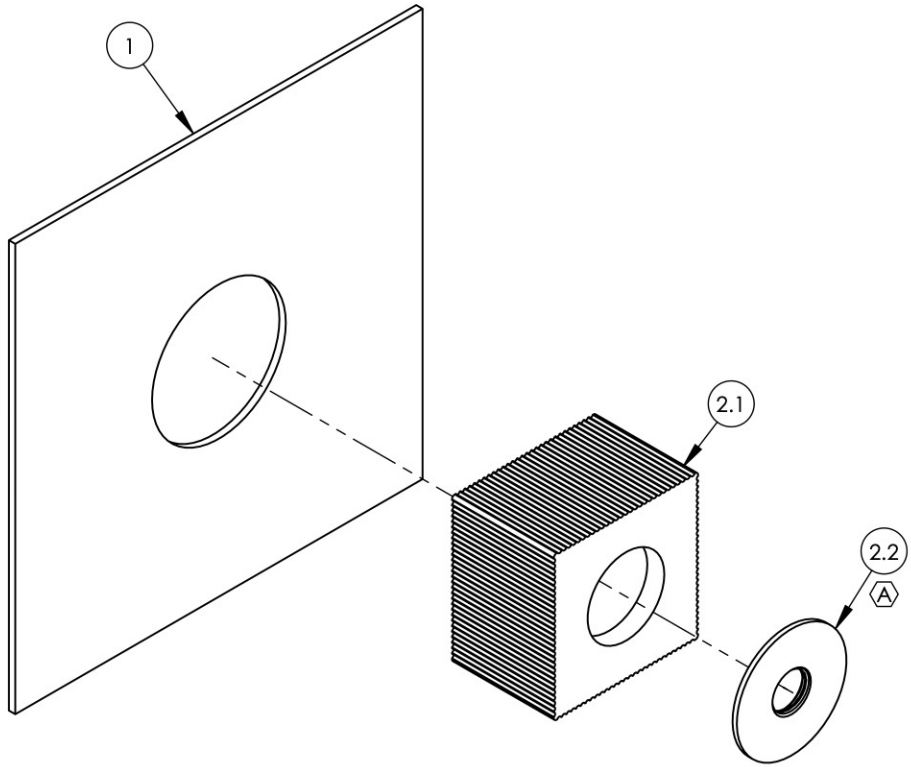

| ZONE | REV. | DESCRIPTION         | DATE     | APPROVED |
|------|------|---------------------|----------|----------|
| A1   | A    | ADDED ADAPTER PLATE | 8/1/2023 | LFV      |

REVISIONS

|   |  |  |
|---|--|--|
| 1261 LOGAN AVENUE<br>COSTA MESA, CALIFORNIA 92626<br><br>PHONE: 714.361.4800<br>FAX: 714.617.3120 | <h1 style="margin: 0;">PHYL RICH<sup>®</sup></h1> <p style="margin: 0;">Defining Luxury Since 1959</p> | <b>PROPRIETARY AND CONFIDENTIAL</b><br><br><small>THE INFORMATION CONTAINED IN THIS DRAWING IS THE SOLE PROPERTY OF RSS MANUFACTURING. ANY REPRODUCTION IN PART OR AS A WHOLE WITHOUT THE WRITTEN PERMISSION OF RSS MANUFACTURING IS PROHIBITED.</small> |
|---|--|--|

|                             |         |   |      |           |
|-----------------------------|---------|---|------|-----------|
| NEXT ASSY                   | USED ON | INTERPRET GEOMETRIC DIMENSIONING & TOLERANCING IN ACCORDANCE WITH ASME Y14.5-2009 & ASME Y14.41-2003 STANDARDS, UNLESS OTHERWISE SPECIFIED. DIMENSIONS ARE IN INCHES. TOLERANCES ARE:<br><br><b>FRACTIONS</b> ±1/64"<br><b>DECIMALS</b> X.X: ±.1<br>X.XX: ±.01<br>X.XXX: ±.005<br><br><b>ANGULAR</b> ±.5° |      |           |
| APPLICATION                 |         |   |      |           |
| MATERIAL                    |         | NAME  | DATE |           |
| FINISH                      |         | DRAWN   | LLO  | 8/19/2016 |
| <b>DO NOT SCALE DRAWING</b> |         | CHECKED   | GRE  |           |

|  |                 |              |  |
|--|-----------------|--------------|--|
| <b>STRIA EXT. TRIM PB/TH PLATE &amp; HUB ASSY.</b> |                 |              |  |
| SIZE   | ASM/PRT NO.     | REV          |  |
| <b>A</b>   | <b>3-428/00</b> | <b>A</b>     |  |
| SCALE: 1:2   | WEIGHT: lbs.    | SHEET 1 OF 1 |  |

5

4

3

2

1

A

B

C

D

E