

ITEM NO.	PART NUMBER	DESCRIPTION	QTY.
1	11338/00	MIX/STRIA SQ. PLATE FOR EXT.	1
2	2-424/00	MIX DEEP EXT. HUB ASSY W/ ADAPTER	1
2.1	11336/00	MIX DEEP ESCUTCHEON	1
2.2	11341	HUB ADAPTER FOR EXT. DEEP HUB	1

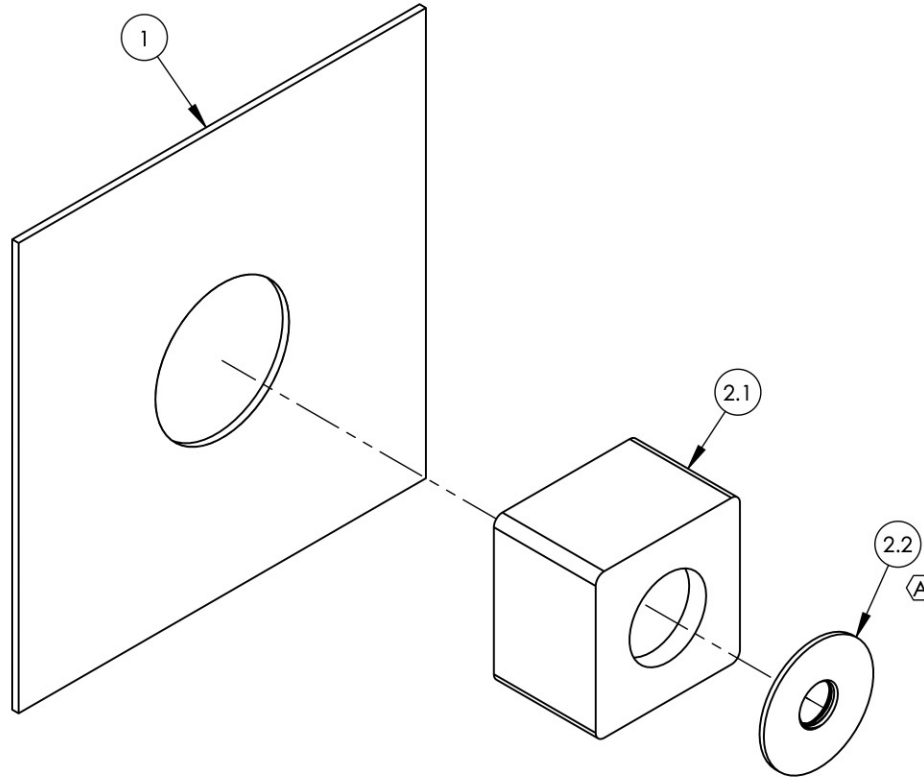

ZONE	REV.	DESCRIPTION	DATE	APPROVED
A1	A	ADDED ADAPTOR PLATE	8/1/2023	LFV

REVISIONS

1261 LOGAN AVENUE COSTA MESA, CALIFORNIA 92626 PHONE: 714.361.4800 FAX: 714.617.3120	<h1>PHYL RICH®</h1> <p>Defining Luxury Since 1959</p>	PROPRIETARY AND CONFIDENTIAL <small>THE INFORMATION CONTAINED IN THIS DRAWING IS THE SOLE PROPERTY OF RSS MANUFACTURING. ANY REPRODUCTION IN PART OR AS A WHOLE WITHOUT THE WRITTEN PERMISSION OF RSS MANUFACTURING IS PROHIBITED.</small>
---	---	--

NEXT ASSY	USED ON	INTERPRET GEOMETRIC DIMENSIONING & TOLERANCING IN ACCORDANCE WITH ASME Y14.5-2009 & ASME Y14.41-2003 STANDARDS, UNLESS OTHERWISE SPECIFIED. DIMENSIONS ARE IN INCHES. TOLERANCES ARE: FRACTIONS ±1/64" DECIMALS X.X: ±.1 X.XX: ±.01 X.XXX: ±.005 ANGULAR ±.5°		
APPLICATION				
MATERIAL		NAME	DATE	
FINISH		DRAWN	LLO	8/19/2016
DO NOT SCALE DRAWING		CHECKED	GRE	

MIX EXT. TRIM PB/TH PLATE & HUB ASSY.			
SIZE	ASM/PRT NO.	REV	
A	3-427/00	A	
SCALE: 1:2	WEIGHT: lbs.	SHEET 1 OF 1	

5

4

3

2

1

A

B

C

D

E