

NOTE(S):

1. PART NUMBER, "/00" DENOTES PART SHALL HAVE FINISH.
2. APPLY NSF COMPLIANT GREASE TO ANY O-RING, SEALING JOINTS, AND/OR PIVOTAL POINTS.
3. APPLY NSF COMPLIANT LOCTITE TO THREADED AREA.
4. APPLY NSF COMPLIANT REMOVABLE (BLUE) LOCTITE TO THREADED AREA.
5. SILVER SOLDER JOINTS SHALL BE FULLY WETTED VIA CAPILLARY ACTION AND COMPLETELY NON-POROUS.

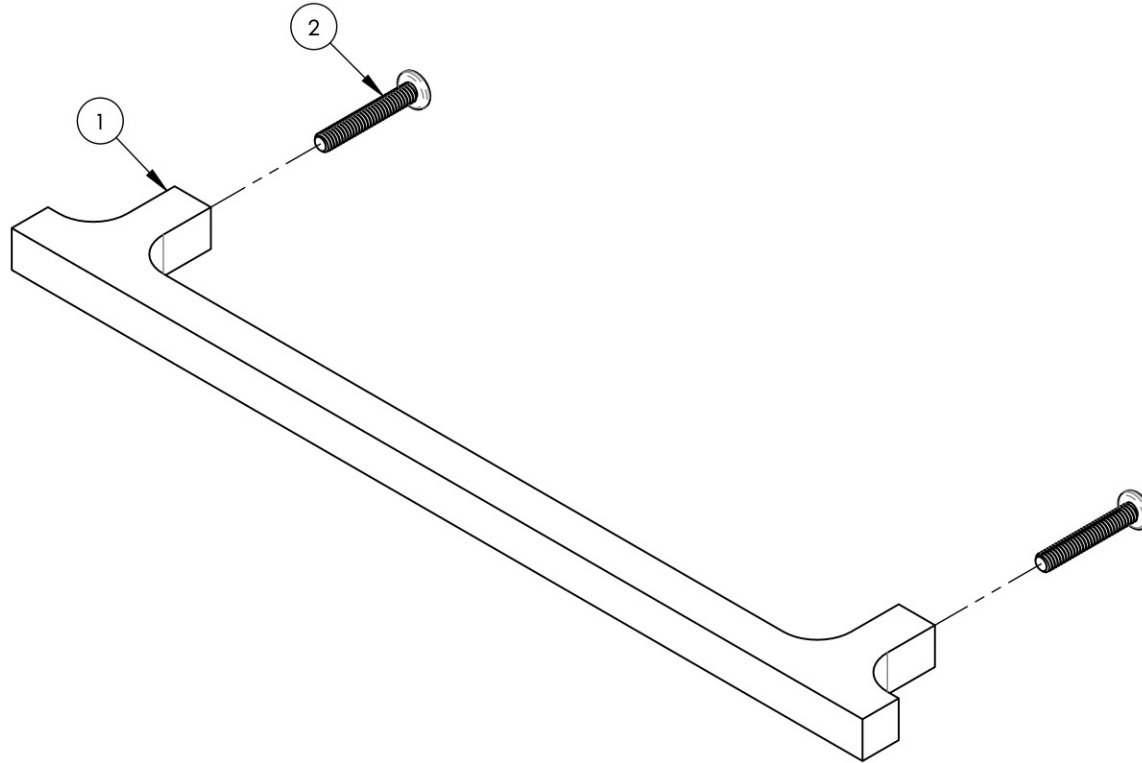

ITEM NO.	PART NUMBER	DESCRIPTION	QTY.
1	50169	CABINET PULL, 8", CROI	1
2	92095	SCREW, PHILIPS HD 8-32 X 1"L	2



ZONE	REV.	DESCRIPTION	DATE	APPROVED
------	------	-------------	------	----------

REVISIONS

1261 LOGAN AVENUE
COSTA MESA, CALIFORNIA 92626
PHONE: 714.361.4800
FAX: 714.617.3120

PHYLIRICH[®]
Defining Luxury Since 1959

PROPRIETARY AND CONFIDENTIAL
THE INFORMATION CONTAINED IN THIS DRAWING IS THE SOLE PROPERTY OF PHYLIRICH. ANY REPRODUCTION IN PART OR AS A WHOLE WITHOUT THE WRITTEN PERMISSION OF PHYLIRICH IS PROHIBITED.
DO NOT SCALE DRAWING

ASSY, PULL, CABINET, 8", CROI

SIZE A	ASM/PRT NO. 255-91-08/00	REV -
------------------	-----------------------------	----------

SCALE: 1:1.5 WEIGHT: lbs. SHEET 1 OF 2