

5

4

3

2

1

NOTE(S):

- 1. PART NUMBER, "/00" DENOTES PART SHALL HAVE FINISH.
- 2. APPLY NSF COMPLIANT GREASE TO ANY O-RING, SEALING JOINTS, AND/OR PIVOTAL POINTS.
- 3. APPLY NSF COMPLIANT LOCTITE TO THREADED AREA.
- 4. APPLY NSF COMPLIANT REMOVABLE (BLUE) LOCTITE TO THREADED AREA.
- 5. SILVER SOLDER JOINTS SHALL BE FULLY WETTED VIA CAPILLARY ACTION AND COMPLETELY NON-POROUS.



ITEM NO.	PART NUMBER	DESCRIPTION	QTY.
1	11337/00	STRIA DEEP ESCUTCHEON	1
2	11341	HUB ADAPTER FOR EXT. DEEP HUB	1

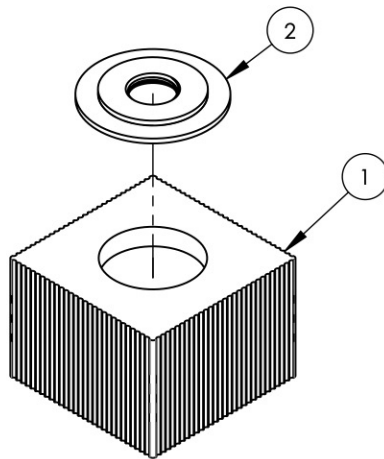

ZONE	REV.	DESCRIPTION	DATE	APPROVED
REVISIONS				

1261 LOGAN AVENUE
COSTA MESA, CALIFORNIA 92626
PHONE: 714.361.4800
FAX: 714.617.3120

PHYLIRICH[®]
Defining Luxury Since 1959

PROPRIETARY AND CONFIDENTIAL
THE INFORMATION CONTAINED IN THIS DRAWING IS THE SOLE PROPERTY OF PHYLIRICH. ANY REPRODUCTION IN PART OR AS A WHOLE WITHOUT THE WRITTEN PERMISSION OF PHYLIRICH IS PROHIBITED.

-	-	INTERPRET GEOMETRIC DIMENSIONING & TOLERANCING IN ACCORDANCE WITH ASME Y14.5-2009 & ASME Y14.41-2003 STANDARDS, UNLESS OTHERWISE SPECIFIED. DIMENSIONS ARE IN INCHES. TOLERANCES ARE:		
-	-			
-	-			
NEXT ASSY	USED ON	FRACTIONS ±1/16"	DECIMALS X.X: ±.1 X.XX: ±.01 X.XXX: ±.005	ANGULAR ±2°
APPLICATION			NAME	DATE
MATERIAL			DRAWN	
FINISH			CHECKED	
DO NOT SCALE DRAWING				

SIZE A	ASM/PRT NO.	REV
SCALE: 1:2	WEIGHT: lbs.	SHEET 1 OF 1

5

4

3

2

1