

NOTE(S):
 1. PART NUMBER, "/00" DENOTES PART SHALL HAVE FINISH.

2. APPLY NSF COMPLIANT GREASE TO ANY O-RING, SEALING JOINTS, AND/OR PIVOTAL POINTS. G

3. APPLY NSF COMPLIANT LOCTITE TO THREADED AREA. L

4. APPLY NSF COMPLIANT REMOVABLE (BLUE) LOCTITE TO THREADED AREA. B

5. SILVER SOLDER JOINTS SHALL BE FULLY WETTED VIA CAPILLARY ACTION AND COMPLETELY NON-POROUS. S

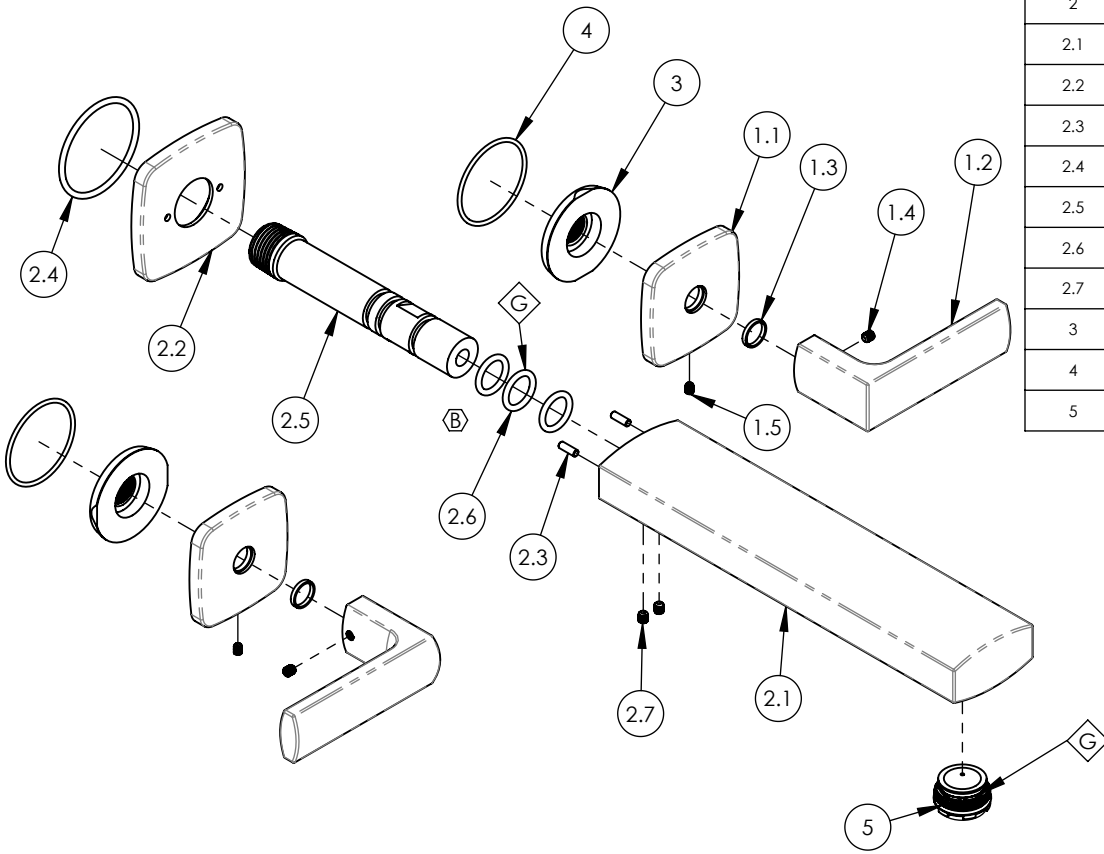

ITEM NO.	PART NUMBER	DESCRIPTION	QTY.
1	3-520/00	ASSY, LEVER HANDLE, RADII	2
1.1	11620/00	ESCUTCHEON, HANDLE RADII	1
1.2	11622/00	HANDLE, LEVER, RADII	1
1.3	92176	WEAR WASHER	1
1.4	92008	SET SCREW, CUP POINT 8-32, 3/16" L.	1
1.5	92005	SET SCREW, CUP PT 6-32 UNC THREAD 3/16"L	1
2	3-523/00	ASSY, WALL SPOUT, RADII	1
2.1	11628/00	WALL SPOUT, RADII	1
2.2	11629/00	ESCUTCHEON, WALL SPOUT, RADII	1
2.3	92158	DOWEL PIN, 1/8" X 3/8"L	2
2.4	90131	O-RING, 1-11/16ID X 3/32THK, AS-568-131	1
2.5	10013	INJECTOR SHANK, 1/2"NPT MALE TO M16.5 CACHE W/ O-SEAL	1
2.6	90113	O-RING, 9/16"ID X 3/4"OD X 3/32"THK, AS-568-113	3
2.7	92008	SET SCREW, CUP POINT 8-32, 3/16" L.	2
3	11003	SLEEVE MOUNT, WALL MT WIDESPREAD	2
4	90029	O-RING, 1-5/8"ID X 1-3/4"OD X 1/16"THK, AS-568-029	2
5	P05051	AERATOR, CACHE COINED SLOT M24X1.0 FULL FLOW	1

ZONE	REV.	DESCRIPTION	DATE	APPROVED
C4	B	UPDATE O-RINGS	6/10/2021	AMM
REVISIONS				

1261 LOGAN AVENUE
 COSTA MESA, CALIFORNIA 92626
 PHONE: 714.361.4800
 FAX: 714.617.3120

PHYLIRICH[®]
 Defining Luxury Since 1959

PROPRIETARY AND CONFIDENTIAL
 THE INFORMATION CONTAINED IN THIS DRAWING IS THE SOLE PROPERTY OF PHYLIRICH. ANY REPRODUCTION IN PART OR AS A WHOLE WITHOUT THE WRITTEN PERMISSION OF PHYLIRICH IS PROHIBITED.
DO NOT SCALE DRAWING

WALL TUB SET, LEVER HANDLES, RADII

SIZE A	ASM/PRT NO. 181-57/00	REV B
SCALE: 1:3.25	WEIGHT: lbs.	SHEET 1 OF 2

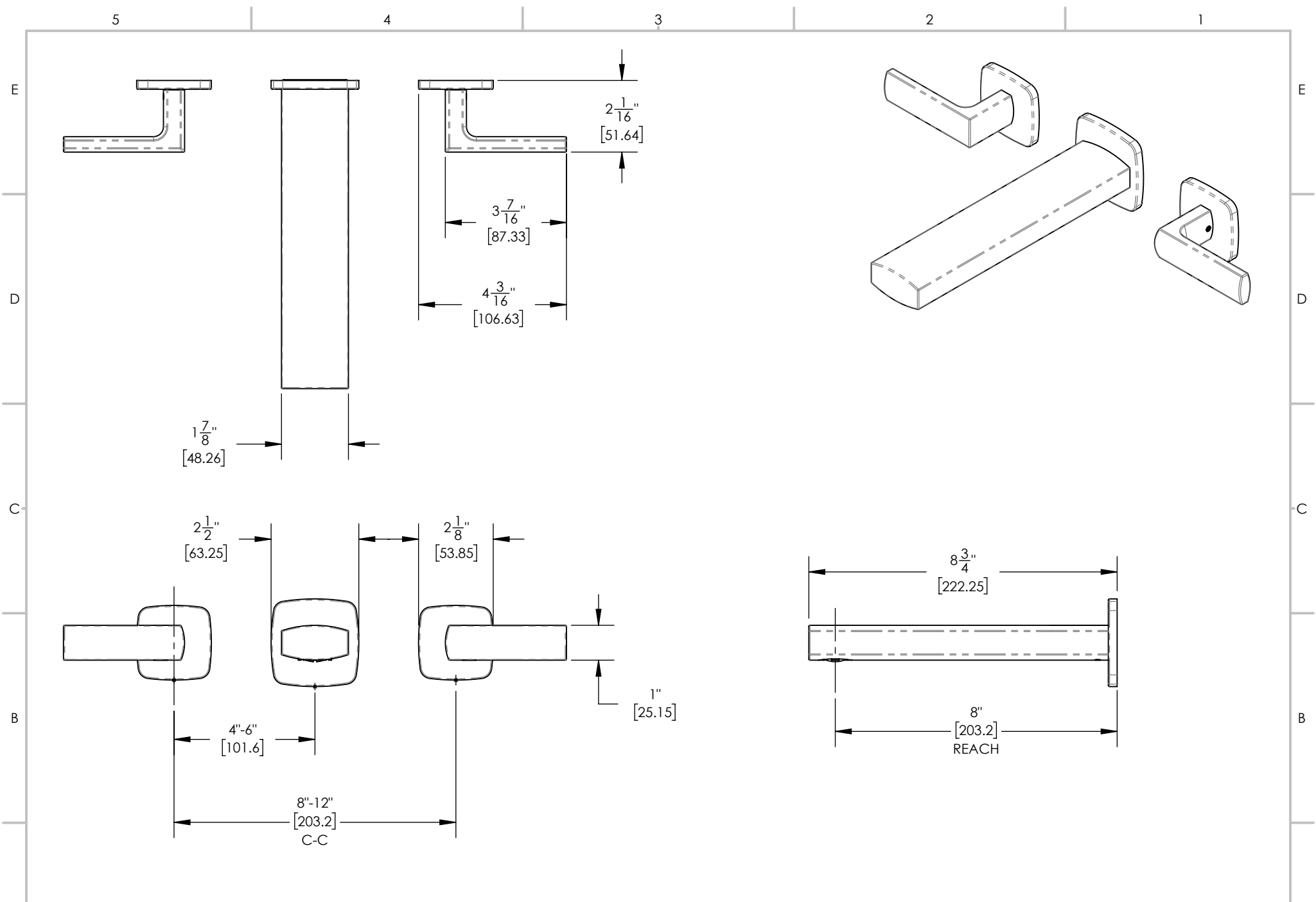

1261 LOGAN AVENUE
 COSTA MESA, CALIFORNIA 92626
 PHONE: 714.361.4800
 FAX: 714.617.3120

PHYLIRICH[®]
 Defining Luxury Since 1959

PROPRIETARY AND CONFIDENTIAL
 THE INFORMATION CONTAINED IN THIS DRAWING
 IS THE SOLE PROPERTY OF PHYLIRICH. ANY
 REPRODUCTION IN PART OR AS A WHOLE
 WITHOUT THE WRITTEN PERMISSION OF PHYLIRICH
 IS PROHIBITED.
DO NOT SCALE DRAWING

WALL TUB SET, LEVER HANDLES, RADI

SIZE A	ASM/PRT NO. 181-57/00	REV B
SCALE: 1:3.5	WEIGHT: lbs.	SHEET 2 OF 2

A

A