

NOTE(S):
 1. PART NUMBER, "/00" DENOTES PART SHALL HAVE FINISH.
 2. APPLY NSF COMPLIANT GREASE TO ANY O-RING, SEALING JOINTS, AND/OR PIVOTAL POINTS.
 3. APPLY NSF COMPLIANT LOCTITE TO THREADED AREA.

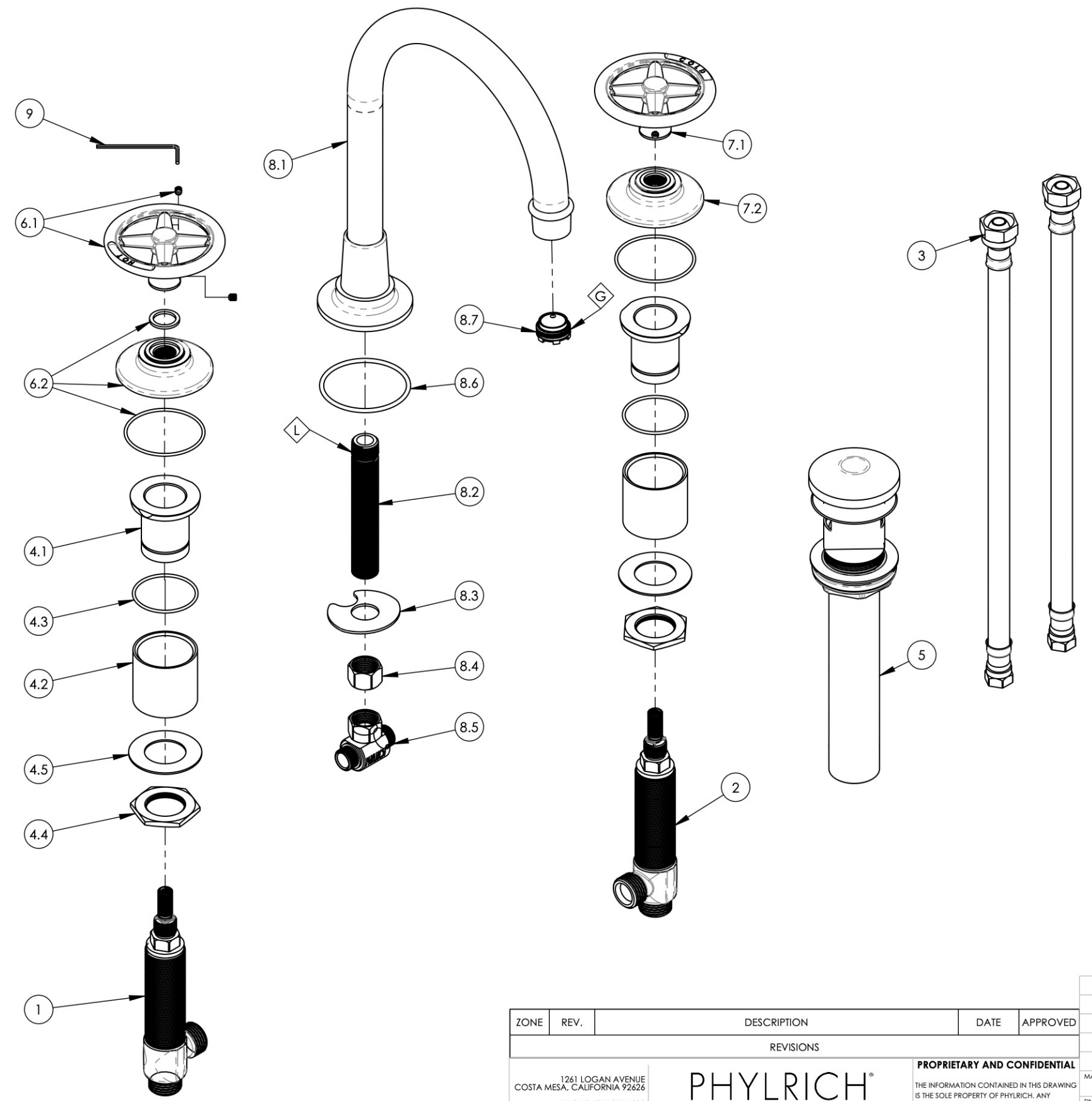

ITEM NO.	PART NUMBER	DESCRIPTION	QTY.
1	1-149	WIDESPREAD VALVE LAV 1/2PT, HOT, ONLY	1
2	1-150	WIDESPREAD VALVE LAV 1/2PT, COLD, ONLY	1
3	10982	HOSE, 3/8" COMP. X 1/2" NPSM - 12'L	2
4	2-092	RECESSED MOUNTING KIT FOR WIDESPREAD	2
4.1	10998	SLEEVE MOUNT, WIDESPREAD	1
4.2	92180	EXTENSION SLEEVE, WIDESPREAD	1
4.3	90029	O-RING, 1-5/8"ID X 1-3/4"OD X 1/16"THK, AS-568-029	1
4.4	92251	HEX NUT, 1"-20 THREAD	1
4.5	92252	WASHER, 1-1/32" ID 1-13/16" OD	1
5	3-545/00	BRASS PUSH TYPE DRAIN, W/ OVERFLOW & SMALL PLUG	1
6	3-612/00	HANDLE CROSS HOT, W/ BASE & HARDWARE, WORKS	1
6.1	3-300/00	HANDLE CROSS, HOT, W/ HARDWARE, WORKS	1
6.2	3-299/00	ESCUTCHEON BASE FOR HANDLE, WORKS	1
7	3-613/00	HANDLE CROSS COLD, W/ BASE & HARDWARE, WORKS	1
7.1	3-301/00	HANDLE CROSS, COLD, W/ HARDWARE, WORKS	1
7.2	3-299/00	ESCUTCHEON BASE FOR HANDLE, WORKS	1
8	3-616/00	SPOUT ARC, WIDESPREAD, W/ HARDWARE, TRADITIONAL, WORKS	1
8.1	2-331/00	SPOUT ARC, BASE & AERATOR HOUSING, BRAZE, WORKS	1
8.2	10745	THREAD ALL, 3/8"-18 NPSL - 3/8"NPT	1
8.3	92174	WASHER MOUNT WIDESPREAD (3/8")	1
8.4	10746	NUT, 3/8"-18 NPSL	1
8.5	1-112	TEE VALVE, 3/8" NPSM X 3/8" COMPRESSION	1
8.6	90137	O-RING, 2-1/16"ID X 3/32"THK., AS-568-137	1
8.7	11429	AERATOR CACHE JUNIOR, 1.2GPM, M21.5X1.0, NEOPERL # 42.2260.450	1
9	P39001	HEX KEY 5/64, FOR 8-32 SET SCREW	1

ZONE	REV.	DESCRIPTION	DATE	APPROVED
REVISIONS				
1261 LOGAN AVENUE COSTA MESA, CALIFORNIA 92626 PHONE: 714.361.4800 FAX: 714.617.3120				
PROPRIETARY AND CONFIDENTIAL THE INFORMATION CONTAINED IN THIS DRAWING IS THE SOLE PROPERTY OF PHYLIRICH. ANY REPRODUCTION IN PART OR AS A WHOLE WITHOUT THE WRITTEN PERMISSION OF PHYLIRICH IS PROHIBITED.				

INTERPRET GEOMETRIC DIMENSIONING & TOLERANCING IN ACCORDANCE WITH ASME Y14.5-2009 & ASME Y14.41-2003 STANDARDS. UNLESS OTHERWISE SPECIFIED, DIMENSIONS ARE IN INCHES. TOLERANCES ARE:		
FRACTIONS ±1/16"	DECIMALS X.X: ±.1 X.XX: ±.01 X.XXX: ±.005	ANGULAR ±2°
NEXT ASSY	USED ON	APPLICATION
MATERIAL	NAME	DATE
FINISH	DRAWN RAH	6/27/2019
DO NOT SCALE DRAWING	CHECKED	

WIDESPREAD LAV, ARC SPOUT W/ CROSS, WORKS		
SIZE	ASM/PRT NO.	REV
B	220-01/00	-
SCALE: 1:3	WEIGHT: lbs.	SHEET 1 OF 2