

5

4

3

2

1

E

E

D

D

C

C

B

B

ITEM NO.	PART NUMBER	DESCRIPTION	QTY.
1	11003	SLEEVE MOUNT, WALL MT WIDESPREAD	1
2	3-595/00	ASSY, BLADE HANDLE, DIAMA	1
2.1	11762/00	BLADE HANDLE, DIAMA	1
2.2	11764/00	ESCUTCHEON, HANDLE, DIAMA	1
2.3	92005	SET SCREW, CUP PT 6-32 UNC THREAD 3/16"L	1
2.4	92176	WEAR WASHER	2
2.5	92177	RETAINING RING, 7/16" SHAFT	1
3	90029	O-RING, 1-5/8"ID X 1-3/4"OD X 1/16"THK, AS-568-029	1

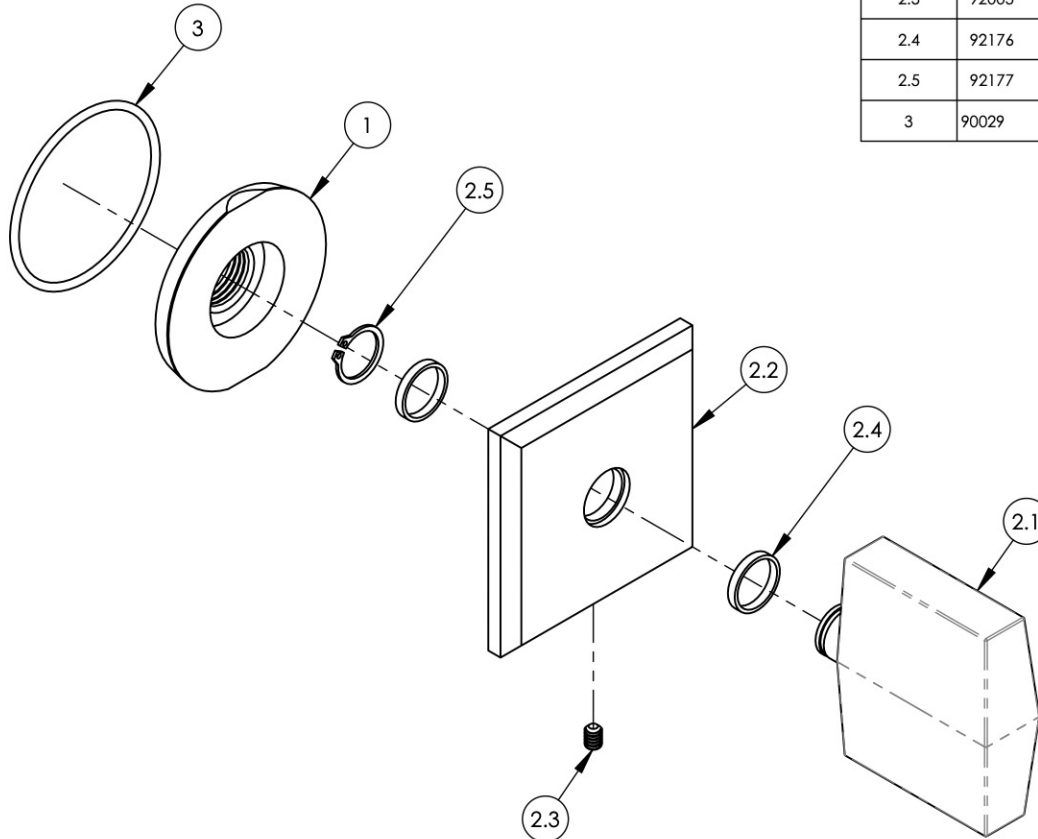

ALL	A	UPDATE TEMPLATE	6/11/2020	AMM
ZONE	REV.	DESCRIPTION	DATE	APPROVED
REVISIONS				

1261 LOGAN AVENUE
COSTA MESA, CALIFORNIA 92626
PHONE: 714.361.4800
FAX: 714.617.3120

PHYL RICH[®]
Defining Luxury Since 1959

PROPRIETARY AND CONFIDENTIAL
THE INFORMATION CONTAINED IN THIS DRAWING IS THE SOLE PROPERTY OF PHYL RICH. ANY REPRODUCTION IN PART OR AS A WHOLE WITHOUT THE WRITTEN PERMISSION OF PHYL RICH IS PROHIBITED.

-	-	INTERPRET GEOMETRIC DIMENSIONING & TOLERANCING IN ACCORDANCE WITH ASME Y14.5-2009 & ASME Y14.41-2003 STANDARDS, UNLESS OTHERWISE SPECIFIED. DIMENSIONS ARE IN INCHES. TOLERANCES ARE:		
NEXT ASSY	USED ON	FRACTIONS ±1/16"	DECIMALS X.X: ±.1 X.XX: ±.01 X.XXX: ±.005	ANGULAR ±2°
APPLICATION		MATERIAL	NAME	DATE
FINISH		DRAWN	AMM	2/8/2019
DO NOT SCALE DRAWING		CHECKED		

SHOWER/VOLUME CONTROL DIVERTER TRIM, BLADE HANDLES, DIAMA

SIZE	ASM/PRT NO.	REV
A	184-35/00	A

SCALE: 1:1.5 WEIGHT: lbs. SHEET 1 OF 2

5

4

3

2

1

A

A